

# General Specifications

## Model UT350 Digital Indicating Controller



GS 05D01D02-01E

### General

Model UT350 Digital Indicating Controller is a highly accurate 1/4DIN controller provided with universal input/output. It has a large display for readings and excellent monitoring operability with the Auto/Man switching key. In addition, heating/cooling control, including PID control with auto-tuning, the "SUPER" overshoot suppressing function "SUPER" and the hunting suppressing function "SUPER2" are available as control functions, and a retransmission of variables and a 15 V DC loop power supply are also equipped as standard. A communication function or 24 V DC loop power supply is available optionally. As described above, the UT350 is a controller provided with higher functions and capability than conventional similar-size controllers.

### Main Features

- Extra-large digital display allows the indicated values to be read even from a long distance. LEDs of 20mm height are used for the process variable display.
- Universal input and output enable users to set or change freely the type of measured inputs(thermocouple, RTD, or DCV), measurement range, type of control output(4 to 20 mA current, voltage pulse, or relay contact), from the front panel.
- Parameters can be easily set using a personal computer. ("Parameter setting tool (model LL100)" sold separately is required.)
- Various communication functions are provided. Communication is possible with personal computer, programmable logic controller, and other controllers.

### Functional Specifications

#### Control Computation Functions

Control computation:

Can be selected from the following types:  
Continuous PID control, Time-proportional PID control, Heating/Cooling control (for heating/cooling type only) or Relay ON/OFF control.

Control cycle time: 250 ms

Number of sets of target setpoints and PID parameters: 4

Target setpoint and PID selection:

PID parameters are provided for every target setpoint and the set of PID parameters are selected at the same time that the setpoint number is selected.

Zone PID selection:

PID parameters are selected depending on the value of the PV. For selection, the reference point (PID parameter selection setpoint) or the reference deviation is used.

Reference point method:

The measuring input range is divided into a maximum of three zones with up to two reference points, and PID parameters are selected (No. 1 PID to No. 3 PID) for every zone.

### UT350



#### UT350E

"E" indicates the model with expanded functions.

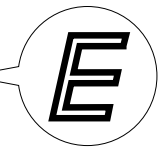

Reference point = Measuring input range (0%)  $\cong$  Reference point 1  $\cong$  Reference point 2  $\cong$  Measuring input range (100%)

Reference point hysteresis = Fixed to 0.5% of the measured input range span.

Reference deviation method:

PID parameters (No. 4 PID) are selected when the deviation exceeds the reference deviation. This process takes precedence over the reference point method.

Reference deviation = OFF or 0.1 to 100.0% of measured input range span

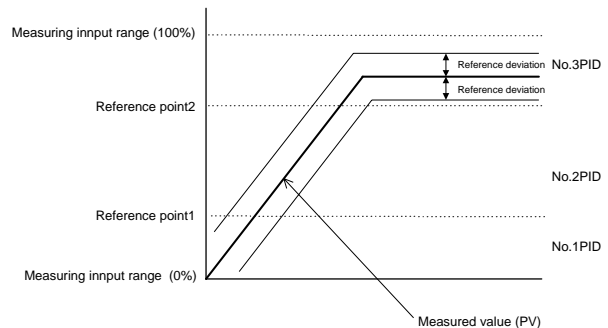

Auto-tuning:

Available as standard. If auto-tuning is operated, PID constants are automatically set (limit cycle method).

"SUPER" function:

Overshoots generated by abrupt changes in the target setpoint or by disturbances can be suppressed.

"SUPER2" function:

The function stabilizes the state of control that is unstable due to hunting, etc. without requiring any change in PID constants, when the load and/or gain varies greatly, or when there is a difference between the characteristics of temperature zones.

## Control Parameters Setting Range

- Proportional band = 0.1 to 999.9%  
 0.0 to 999.9% for heating/cooling control,  
 0.0% for ON/OFF control
- Integral time = 1 to 6,000s, or OFF (manual reset)
- Derivative time = 1 to 6,000s, or OFF
- Manual reset value = -5.0 to 105.0% of output range  
 (functions when integral time is off.)
- ON/OFF control hysteresis = 0.0 to 100.0% of measured  
 input range span (0.1 to 0.5% for heating/  
 cooling control)
- Setpoint rate-of-change setting = off, or 0.0 to 100.0%/h or  
 min of measured input range span.  
 A PV tracking function operates automatically  
 when the setpoint is changed, the power is  
 turned on, or the mode is changed from  
 manual to automatic.
- Direct/reverse action:  
 The output increase/decrease direction can be  
 defined corresponding to a positive or  
 negative deviation.  
 For heating/cooling control, it is fixed; for the  
 heating side output, reverse, for the cooling  
 side output, direct.
- Anti-reset windup:  
 When controller output is limited, normal  
 integration is superseded by an anti-reset  
 windup computation to suppress over-  
 integration.
- Control output cycle time = 1 to 1000 s (for Time-  
 proportional PID control) (the cooling side  
 output cycle time is also the same when  
 heating/cooling control is used).
- Preset output value = -5.0 to 105.0% of output range
- Output tracking:  
 Whether the output bump is provided or not  
 can be selected by changing the PID control  
 mode.
- Output limiter  
 Upper limit = Lower limit to 105.0% of output  
 range  
 Lower limit = -5.0% of output range to upper  
 limit
- Heating/cooling dead band = -100.0 to 50.0% for output  
 range

## ● Signal Computation Functions

- Measured input computation:  
 Bias addition (-100.0 to 100.0% of measured  
 input range span), and first-order lag filter  
 (time constant off or 1 to 120 s)
- Contact input function:  
 Target setpoint selection, Auto/Man operating  
 mode switching, key lock parameter display/  
 non-display switching  
 Target setpoint selection can be done for  
 either a 2-setpoint or 4-setpoint selection.
- If the 2-setpoint selection is set, Auto/Man  
 mode switching can be used as well.
  - If the 4-setpoint selection is set, Auto/Man  
 switching and key lock parameter display/non-  
 display switching cannot be used together.
- If key lock parameter display/non-display  
 switching is used, target setpoint selection and  
 Auto/Man mode switching cannot be used.

## ● Alarm Functions

Eighteen types of alarm functions are provided. The alarm  
 status is indicated by the alarm lamp on the front panel.  
 Also, three points among them can be output as relay contact  
 outputs.

Alarm types:

PV high limit, PV low limit, Deviation high  
 limit, Deviation low limit, Deenergized on  
 deviation high limit, Deenergized on deviation  
 low limit, Deviation high and low limits, High  
 and low limits within deviation, Deenergized  
 on PV high limit, Deenergized on PV low  
 limit, SP high limit, SP low limit, Output high  
 limit, Output low limit, Heater burnout alarm,  
 sensor grounding alarm, Fault diagnostic  
 alarm, FAIL output.

Alarm output:

3 points. Any three points can be output as  
 contact outputs among the above alarms. For  
 heating/cooling control, if cooling side output  
 is output as a relay contact, up to two alarm  
 outputs can be used.

Setting ranges for PV, deviation, setpoint and output alarms:

PV/setpoint alarm:

-100.0 to 100.0% of measured input range

Deviation alarm:

-100.0 to 100.0% of measured input range  
 span

Output alarm:

-5.0 to 105.0% of output range

Alarm hysteresis:

0.0 to 100.0% of measured input range span

Delay timer:

0.00 to 99.59 (minute, second)

An alarm is output when the delay timer  
 expires after the alarm setpoint is reached.

Setting for each alarm is possible.

Stand-by action:

Stand-by action can be set to make PV/  
 deviation alarm OFF during start-up or after  
 SP change until SP reaches the normal region.

Heater burnout alarm (optional):

Two circuits incorporated

A heater burnout alarm is output if the heater  
 current consumption is the burnout detection  
 value or less. This alarm can be used for  
 Relay ON/OFF control or time-proportional  
 PID control.

Heater current setting range: 0.0 to 50.0 A

Setting accuracy:  $\pm 5\%$  of span  $\pm 1$  digit

Heater current detecting resolution: 0.5 A

Time required until burnout detection is on:

0.2 s minimum

burnout sensor model: CTL-6-S-H(URD Co. Ltd.)

Sensor grounding alarm:

An alarm is output after detecting a change in  
 control output. If the moving average \* of  
 control output is out of the setting range  
 (between the high and low limits of the on/off  
 rate) in spite of the deviation being within a  
 fixed range (on/off rate detection band) and  
 control being in stable condition, the sensor is  
 judged to be in a grounding condition.

\* Moving average refers to the average value for output  
 values sampled (five times) in every cycle time.

High- and low-limit setting range of on/off rate:

-5.0 to 105.0% of output range

Detection band of on/off rate:  
0.0 to 100.0% of measured input range span.

Fault diagnostic alarm:  
Input burnout, A/D conversion error,  
thermocouple reference junction compensa-  
tion error

FAIL output:  
Software failure and/or hardware failure  
When in fail, control output, retransmission  
output and alarm output become 0% or OFF.

● **Display and Operation Function**

PV display: In 4-digit digital display for engineering data

Setpoint display:  
Various data, such as the setpoint (SP), are  
displayed by selection on the 4-digit digital  
display.

Status indicating lamps:  
3 alarm indicator lamps: AL1, AL2, AL3  
3 setpoint number indicator lamps:  
SP2, SP3, SP4 (Go out when SP1 is selected.)

MAN operation mode lamp: MAN (lit in MAN mode)

Operation keys:  
△ and ▽ keys:  
Increase or decrease setpoints and various  
parameters.

SET/ENT key:  
Used for data setting or call-up/selection of  
various parameters

A/M key: Switching of operation mode (Auto/Man)

SELECT display:  
A panel where operating parameters that are  
frequently changed during operation can be  
selected and registered. For example, by  
registering the alarm -1 setpoint in the  
SELECT display, the setpoint can easily be  
displayed during operation.

Security function:  
An operation-inhibiting mode using a  
password is provided.

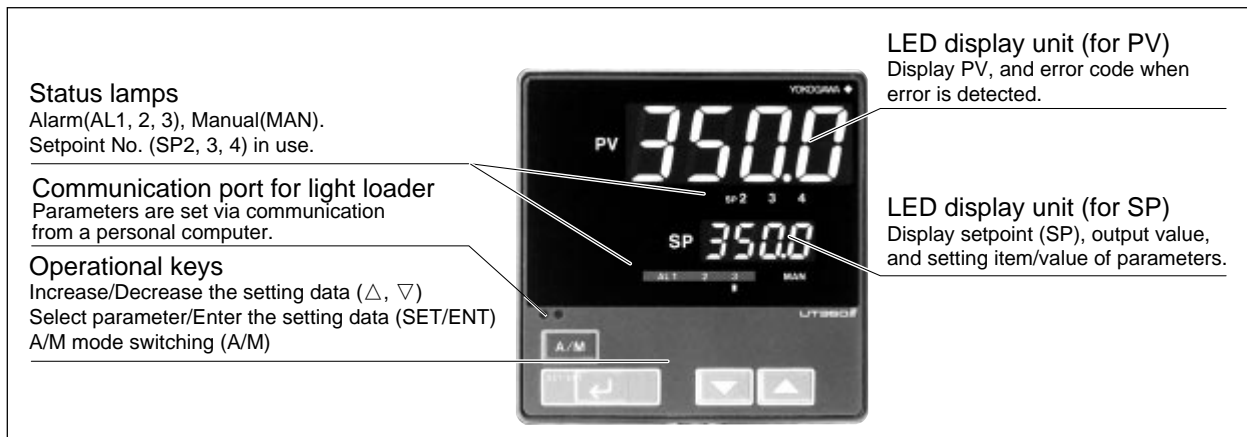

● **Communication Functions(optional)**

This controller has a communication function and can be connected to a personal computer, programmable logic controller or other GREEN series controllers.

Communication protocol

Computer link communication:

Communication protocol with a personal computer.

Ladder communication:

Communication protocol with programmable logic controller.

MODBUS communication:

Communication protocol with a personal computer or PLC.

Coordinated operation:

Communication protocol to coordinated operation with two or more GREEN series controllers. The UT350 can be connected as a master station or a slave station.

Communication interface

Communication protocol:

Computer link, ladder communication, MODBUS or coordinated operation.

Standards: EIA RS485

Maximum number of connectable controllers:

31 GREEN series controllers

Maximum communication distance: 1,200 m

Communication method:

Two-wire half duplex or four-wire half duplex, start-stop synchronization, non-procedural.

Communication rate: 600, 1200, 2400, 4800, or 9600 bps

Examples of Communication System Configuration Diagram

(1) Computer link communication

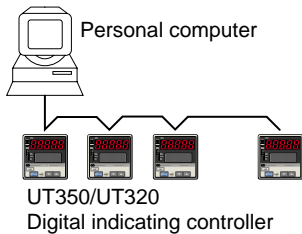

(2) Ladder communication

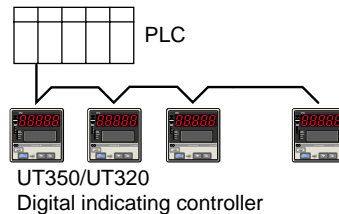

(3) Coordinated operation

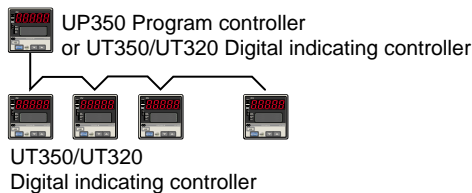

## ■ Hardware Specifications

### Measured Input Signal

Number of input points: 1

Input system:

The types of input/measurement ranges can be set using key operation or software from a list of inputs.

Input type, measurement ranges and measurement accuracy:

Refer to the table below.

Input Type		Input range code	Instrument range (°C)	Instrument range (°F)	Measurement accuracy*1
Unspecified(when shipped from the factory)		OFF	Set the data item PV input Type"IN" to the OFF option to leave the PV input type undefined.		
Thermocouple	K	1	-200 to 1370°C	-300 to 2500°F	±0.1% of instrument range ±1 digit for temperatures equal to or higher than 0 °C, ±0.2% of instrument range ±1 digit for temperatures below 0 °C
		2	-199.9 to 999.9°C	0 to 2300°F	
		3	-199.9 to 500.0°C	-199.9 to 999.9°F	
	J	4	-199.9 to 999.9°C	-300 to 2300°F	
	T	5	-199.9 to 400.0°C	-300 to 750°F	
		6	0.0 to 400.0°C	-199.9 to 750.0°F	
	B	7	0 to 1800°C	32 to 3300°F	±0.15% of instrument range ±1 digit for temperatures equal to or higher than 400 °C ±5% of instrument range ±1 digit for temperatures below 400 °C
	S	8	0 to 1700°C	32 to 3100°F	±0.15% of instrument range ±1 digit
	R	9	0 to 1700°C	32 to 3100°F	
	N	10	-200 to 1300°C	-300 to 2400°F	±0.1% of instrument range ±1 digit ±0.25% of instrument range ±1 digit for temperature below 0 °C
	E	11	-199.9 to 999.9°C	-300 to 1800°F	±0.1% of instrument range ±1 digit for temperatures equal to or higher than 0°C
	L (DIN)	12	-199.9 to 900.0°C	-300 to 1300°F	
	U (DIN)	13	-199.9 to 400.0°C	-300 to 750°F	±0.2% of instrument range ±1 digit for temperatures below 0°C
			0.0 to 400.0°C	-199.9 to 750.0°F	
	W (DIN)	15	0 to 2300°C	32 to 4200°F	±0.2% of instrument range ±1 digit
	Platinel 2	16	0 to 1390°C	32 to 2500°F	±0.1% of instrument range ±1 digit
	PR20-40	17	0 to 1900°C	32 to 3400°F	±0.5% of instrument range ±1 digit for temperatures equal to or higher than 800°C No guarantee of accuracy for temperatures below 800°C
			0 to 2000°C	32 to 3600°F	
RTD	JPt100	30	-199.9 to 500.0°C	-199.9 to 999.9°F	±0.1% of instrument range ±1 digit (Note 1) (Note 2)
		31	-150.0 to 150.0°C	-199.9 to 300.0°F	±0.2% of instrument range ±1 digit (Note 1)
	Pt100	35	-199.9 to 850.0°C	-300 to 1560°F	±0.1% of instrument range ±1 digit (Note 1) (Note 2)
		36	-199.9 to 500.0°C	-199.9 to 999.9°F	±0.1% of instrument range ±1 digit (Note 1) (Note 2)
		37	-150.0 to 150.0°C	-199.9 to 300.0°F	±0.2% of instrument range ±1 digit (Note 1)
Standard signal	0.4 to 2V	40	0.400 to 2.000	Scaling is enable in the following 4 range. -1999 to 9999 -199.9 to 999.9 -19.99 to 99.99 -1.999 to 9.999	±0.1% of instrument range ±1 digit The read-out range can be scaled between -1999 and 9999.
	1 to 5V	41	1.000 to 5.000		
DC voltage	0 to 2V	50	0.000 to 2.000		
	0 to 10V	51	0.00 to 10.00		
	-10 to 20mV	55	-10.00 to 20.00		
	0 to 100mV	56	0.0 to 100.0		

\*1: Performance in the standard operating condition (at 23°C ±2°C, 55±10%RH, and 50/60Hz power frequency)

\*2: To receive a 4 to 20mA DC signal, select a standard signal of 1 to 5V DC and connect it to a 250 ohm resistor. This resistor is optional.

Model & suffix code : X010-250-2 (resistor with M3.5 crimp-on terminal lugs)

Note 1: The accuracy is ±0.3°C of instrument range ±1 digit for a temperature range from 0 to 100°C.

Note 2: The accuracy is ±0.5°C of instrument range ±1 digit for a temperature range from -100 to 0°C and 100 to 200°C.

Sampling period: 250 ms

Burnout detection:

Functions with a thermocouple (TC), RTD, standard signal 0.4 to 2 V DC, and 1 to 5 V DC. Can be specified as upscale, downscale, and off. For standard signal, judged as burnout at 0.1 V or less.

Input bias current: 0.05 µA (for TC/RTD b-terminal)

Measuring current(RTD): about 0.13mA

Input resistance:

1 MΩ or more for TC/mV input  
About 1 MΩ for DC voltage input

Allowable signal source resistance:

250 Ω or less; effect of permissible signal source resistance 0.1 µV/Ω or less for TC/mV input 2 k Ω or less; effect of permissible signal source resistance 0.01%/100 Ω or less for DC voltage input

Allowable leadwire resistance:

Max. of 150 Ω/wire (resistance in each of three wires must be equal) for RTD input However, 10 Ω/wire for a maximum range of -150.0 to 150.0°C.  
Effect of permissible leadwire resistance ±0.1°C/10 Ω or less

Allowable input voltage:  
 ± 10 V DC for TC/mV/RTD input  
 ± 20 V DC for DC voltage input

Noise rejection ratio:  
 Normal mode 40 dB (50/60 Hz) or more  
 Common mode 120 dB (50/60 Hz) or more

Reference-junction compensation error:  
 ± 1.0°C (15 to 35°C),  
 ± 1.5°C (0 to 15°C, 35 to 50°C)

Applicable standards: JIS, IEC, or DIN(ITS-90) for TC and RTD

### 24V DC Loop Power Supply for Sensor

The controller supplies power to a two-wire transmitter. Place a resistor (10 to 250Ω) between the controller and the transmitter, convert a current signal to a voltage signal, and read it from the PV input.

21.6 to 28.0 V DC, maximum supply current is about 30mA (only for models with 24V DC loop power supply).

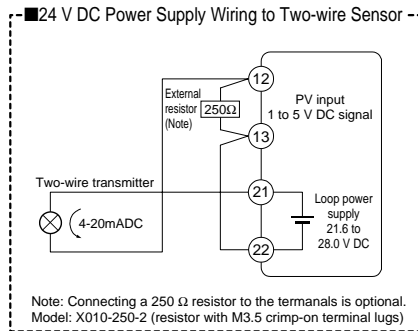

### Retransmission Output

Either PV, target setpoint, or control output is output. Either the retransmission output or the 15V DC loop power supply can be used.

Number of output points: 1  
 Output signal: 4 to 20 mA DC  
 Load resistance: 600 Ω or less  
 Output accuracy: ± 0.3% of span  
 \* Performance in the standard operating conditions (at 23± 2°C, 55± 10% RH, and 50/60 Hz power frequency)

15V DC loop power supply:

Supply voltage is 14.5 to 18.0 V DC. Maximum supply current is about 21 mA (with a protection circuit for a field short-circuit).

### Control Outputs

The control output is of a universal scheme and can be selected from the following types of outputs. In the case of heating/cooling control, it is also selectable from these outputs. However, if the cooling side output is a relay contact output, the alarm-3 cannot be used, and similarly if the cooling side output is a voltage pulse or current output, the retransmission output/15 V DC sensor power supply cannot be used.

Current output  
 Number of output points: 1 or 2 (2 for heating/cooling type), switched between voltage pulse output and current output.  
 Output signal: 4 to 20 mA  
 Load resistance: 600 Ω or less  
 Output accuracy: ±0.3% of span  
 \* Performance in the standard operating conditions (at 23± 2°C, 55± 10% RH, and 50/60 Hz power frequency)

Voltage pulse output  
 Number of output points: 1 or 2 (2 for heating/cooling type), switched between voltage pulse output and current output.  
 Output signal:  
 On voltage = 12 V DC or more (load resistance of 600 Ω or more; current on short-circuiting about 30 mA)  
 Off voltage = 0.1 V DC or less  
 Resolution: 10 ms  
 Relay contact output  
 Number of output points: 1 or 2 (2 for heating/cooling type)  
 Output signal:  
 Three terminals for NC, NO, and Common transfer-contact  
 Contact rating:  
 250 V AC, 3 A or 30 V DC, 3A (resistive load)  
 Resolution: 10 ms

### Contact Inputs

Usage: Target setpoint selection, Auto/Man mode switching, or Key lock parameter display/non-display switching  
 Number of input points: 2  
 Input type: Non-voltage contact input or transistor open collector input  
 Input contact rating: 12 V DC, 10 mA or more (for non-voltage contact input)  
 On/off determination:  
 For non-voltage contact input,  
 ON = contact resistance of 1 kΩ or less,  
 OFF = contact resistance of 20 kΩ or more.  
 For transistor contact input,  
 ON = 2 V or less,  
 OFF = leakage current of 100 μA or less.  
 Minimum retention time for status detection: about 1 second

### Contact Outputs

Usage: Alarm output, FAIL output, and others  
 Number of relay contact output points: 3  
 Relay contact rating: 240 V AC, 1 A or 30 V DC, 1 A (COM terminal is common for every contact output.)

### Display Specifications

PV display:  
 4-digit, 7-segment red LED; character height - 20 mm  
 Setpoint display:  
 4-digit, 7-segment red LED; character height - 9.3 mm  
 Status indicating lamps: LEDs

### Conformance to Safety and EMC Standards

Safety: Compliant with IEC/EN61010-1: 2001, approved by CSA1010, approved by UL508.  
 Installation category : CAT. II (IEC/EN61010, CSA1010) Pollution degree : 2 (IEC/EN61010, CSA1010)  
 Measurement category : I (CAT. I : IEC/EN61010)  
 Rated measurement input voltage : 10V DC max.(across terminals), 300V AC max.(across ground)  
 Rated transient overvoltage : 1500V (Note)  
 Note : It is a value on the safety standard which is assumed by IEC/EN61010-1 in measurement category I, and is not the value which guarantees an apparatus performance.

**EMC standards:**

Complies with EN61326.  
The instrument continues to operate at a measuring accuracy of within  $\pm 20\%$  of the range during tests.

**● Construction, Mounting, and Wiring**

**Construction:** Dust-proof and Drip-proof front panel conforming to IP55.  
For side-by-side close installation, the controller loses its dust-proof and drip-proof protection.

**Material:** ABS resin and polycarbonate

**Case color:** Black

**Weight:** Approx. 1 kg or less

**External dimensions:**

96 (width)  $\times$  96 (height)  $\times$  100 (depth) mm

**Mounting :** Direct panel mounting; mounting bracket, one each for upper and lower mounting

**Panel cutout dimensions:**  $92_{-0}^{+0.8}$  (width)  $\times$   $92_{-0}^{+0.8}$  (height) mm

**Mounting attitude:**

Up to 30 degrees above the horizontal. No downward tilting allowed.

**Wiring:**

M3.5 (ISO 3.5 mm) screw terminals (signal wiring and power/ground wiring as well)

**● Power Supply Specifications and Isolation**

**Power supply:** Rated at 100 to 240 V AC ( $\pm 10\%$ ), 50/60 Hz

**Power consumption:** MAX. 20 VA (MAX. 8.0 W)

**Internal fuse rating:** 250 VAC, 1.6A time-lag fuse

**Memory back-up:** Non-volatile memory (Service life approx. 100,000 times of writings)

**Withstanding voltage:**

1500 V AC for 1 minute between primary and secondary terminals. (Note)

1500 V AC for 1 minute between primary and ground terminals. (Note)

1500 V AC for 1 minute between ground and secondary terminals.

500VAC for 1 minute between two secondary terminals.

(Primary terminals = Power and relay output terminals)  
(Secondary terminals = Analog I/O signal terminals, voltage pulse output terminals, contact input terminals)

Note. The withstanding voltage is specified as 2300V AC per minute to provide a margin of safety.

**Isolation resistance:**

20 M $\Omega$  or more when 500 V DC voltage is applied between the power terminals and ground terminal.

**Grounding:**

Class D grounding (grounding resistance of 100  $\Omega$  or less)

**● Isolation specifications:**

**Measured input terminal:**

Isolated from other I/O terminals. Not isolated from internal circuits.

**15 V DC loop power supply terminals:**

Not isolated from 4-20mA analog output and voltage pulse control output. Isolated from other I/O terminals and internal circuit.

**24 V DC loop power supply terminals:**

Isolated from other I/O terminals and internal circuit.

**Control output (current or voltage pulse) and retransmission terminals:** Not isolated between control output terminals and retransmission output terminals. Isolated from other I/O terminals and internal circuits.

**Relay contact control output terminals:**

Isolated from other I/O terminals and internal circuits.

**Contact input terminals:**

Not isolated from other contact input terminals mutually, and communication terminals. Isolated from other I/O terminals and internal circuits.

**Relay contact alarm output terminals:**

Isolated from other I/O terminals and internal circuits.

**RS-485 communication terminals:**

Not isolated from contact input terminals. Isolated from other I/O terminals and internal circuits.

**Power supply terminals:**

Isolated from other I/O terminals, ground terminal, and internal circuits.

**Ground terminal:**

Isolated from other I/O terminals, power terminals, and internal circuits.

**● Environmental Conditions**

**Normal operating conditions:**

Ambient temperature: 0 to 50°C (40°C or less for mounting of instruments side-by-side)

Ambient temperature change limit: 10°C /h or less

Ambient humidity: 20 to 90% RH (no condensing)

Magnetic field: 400 A/m or less

Continuous vibration (5 to 14 Hz):

Peak-to-peak amplitude of 1.2 mm or less

Continuous vibration (14 to 150 Hz):

4.9 m/s<sup>2</sup> or less

Short-period vibration: 14.7 m/s<sup>2</sup>, 15s or less

Shock: 147 m/s<sup>2</sup> or less, 11 ms

Installation altitude: 2,000 m or less above sea level

Warm-up time 30 minutes or more

**Transportation and storage conditions:**

Temperature: -25 to 70°C

Temperature change limit: 20°C /h or less

Humidity: 5 to 95% RH

**Effects of operating conditions**

**Effect of ambient temperature:**

For voltage or TC inputs:

Whichever is greater,  $\pm 1\mu\text{V}/^\circ\text{C}$  or  $\pm 0.01\%$  of F.S./ $^\circ\text{C}$

For RTD inputs:

$\pm 0.05^\circ\text{C}/^\circ\text{C}$  (ambient temperature) or less for RTD input

For analog output:  $\pm 0.05\%$  of F.S./ $^\circ\text{C}$  or less

**Effect of power supply fluctuation (within rated voltage range):**

For analog input:

Equal to or less than whichever is greater,  $\pm 1\mu\text{V}/10\text{ V}$  or  $\pm 0.01\%$  of F.S./10 V

For analog output:  $\pm 0.05\%$  of F.S./10 V or less

**Function Block Diagram for Standard Type**

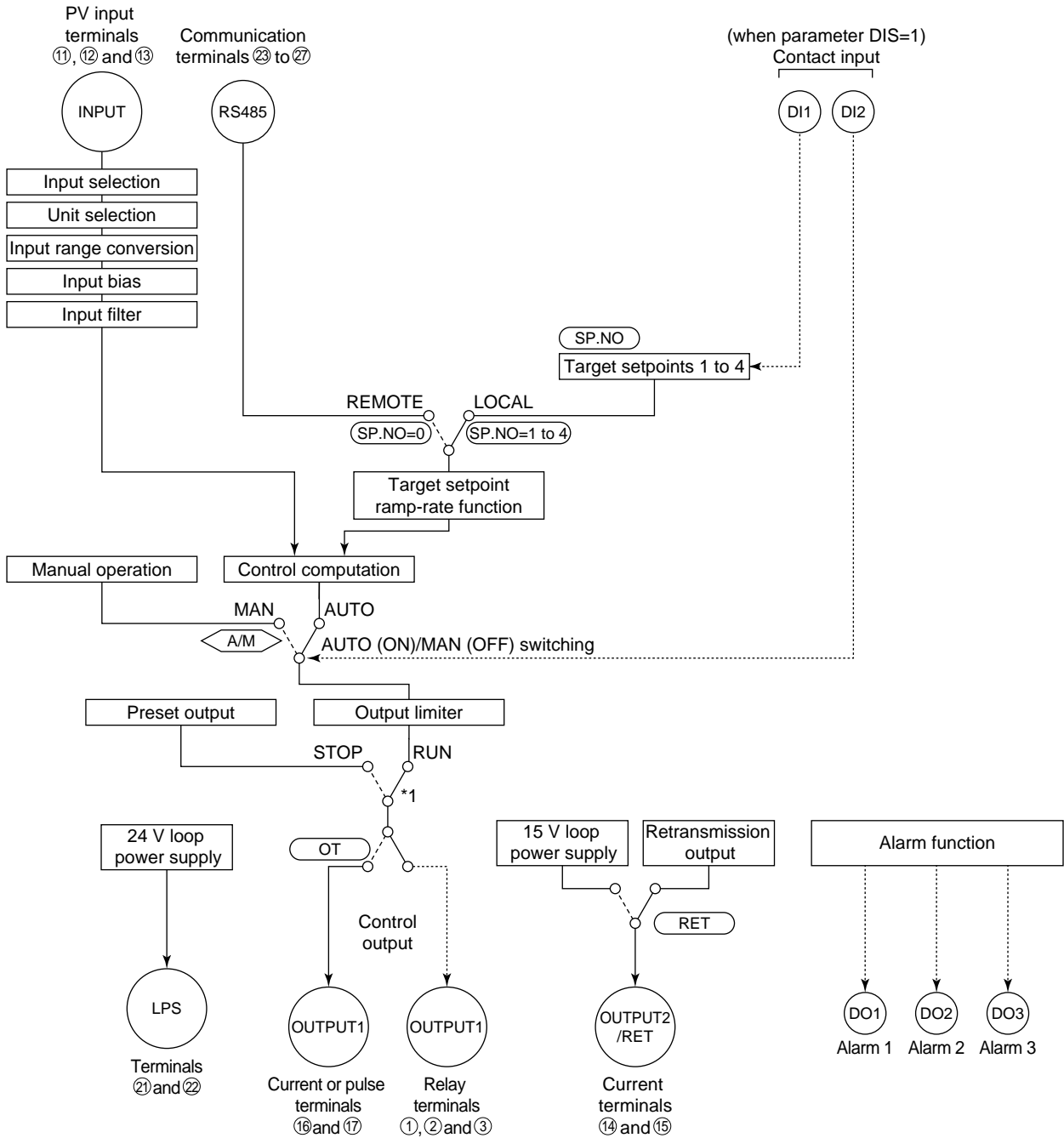

\*1: If the setup parameter DIS (DI function selection) is set to "4", when the contact input 2 is ON (stop state), that controller outputs the preset output value.

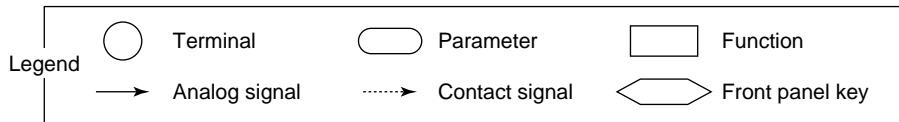



## Function Block Diagram for Heating/Cooling Type

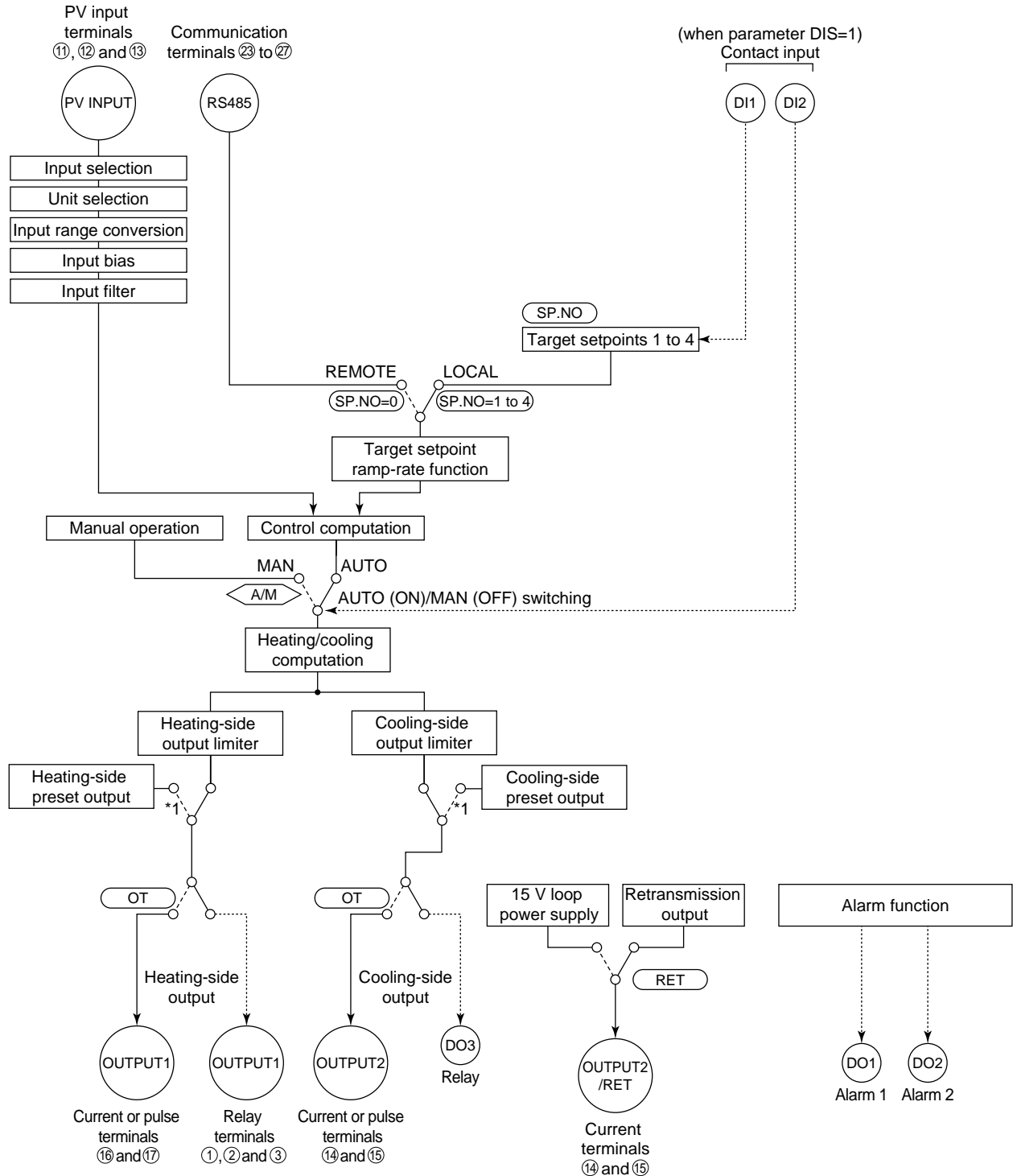

\*1: If the setup parameter DIS (DI function selection) is set to "4",  
 \*1: When the setup parameter DIS (DI function selection) is set to "4",  
 when the contact input 2 is ON (stop state), that controller outputs the preset output value.

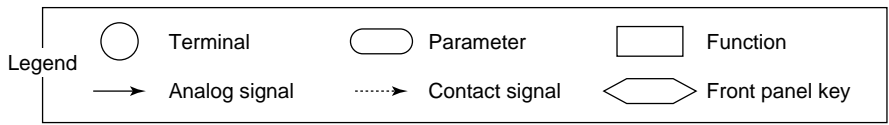

# Standard Type, Terminal Arrangements

**Control output**  
Relay contact output  
NC NO COM  
Contact rating: 250 V AC, 3 A  
30 V DC, 3 A (resistance load)

**Alarm output**  
AL1 AL2 AL3 COM  
Relay contact rating: 240 V AC, 1 A  
30 V DC, 1 A (resistance load)

**Power supply**  
L N  
Allowable range: 100 to 240 V AC (±10%)  
50/60 Hz shared

**CAUTION**  
Before carrying out wiring, turn off the power to the controller and check that cables to be connected are not energized to avoid electric shock.

**RS-485 communication**  
23 SDB(+) 24 SDA(-) 25 RDB(+) 26 RDA(-) 27 SG

**PV input** \* Not configured at factory before shipment  
TC input  
RTD input  
m/V input

**Retransmission output**  
14 15  
4-20 mA DC  
15 V DC loop power supply  
14 15  
14.5-18.0VDC  
(21 mA DC max.)

**Control output**  
Current/voltage pulse output  
16 17  
4-20 mA DC, voltage pulse  
(12 V)

**Heater current detection input**  
29 CT1 28 CT2 30 COM

**External Contact Input**  
+5V L DI1 19 Contact Transistor contact  
+5V DI2 18 COM 20

**Control output**  
Relay contact output  
NC NO COM  
Contact rating: 250 V AC, 3 A  
30 V DC, 3 A (resistance load)

**Alarm output**  
AL1 AL2 AL3 COM  
Relay contact rating: 240 V AC, 1 A  
30 V DC, 1 A (resistance load)

**Power supply**  
L N  
Allowable range: 100 to 240 V AC (±10%)  
50/60 Hz shared

**CAUTION**  
Before carrying out wiring, turn off the power to the controller and check that cables to be connected are not energized to avoid electric shock.

\* Wiring can only be carried out for controllers with 24 V DC loop power supply.

\* Wiring can only be carried out for controllers with communication functions. Maximum baud rate: 9600 bps

Note: Select this option from the OT parameter.  
\* Time proportional PID relay contact output is configured at factory before shipment.

Note: Connecting a 250 Ω resistor to the terminals is optional.  
Model: X010-250-2 (resistor with M3.5 crimp-on terminal lugs)

\* PV retransmission is configured at factory before shipment.

Load resistance: 600 Ω or less  
\* If 15 V DC loop power supply is used, retransmission output cannot be used.

\* This wiring is only possible for a controller with a heater burnout alarm.

\* DIS is a setup parameter. Changing DIS setpoint allows you to change the function of external contact input.

Correspondence between parameter DIS and external contact input functions	
When DIS=OFF	When DIS=1 (Factory-shipped setting) 2.SP when DI1=ON 1.SP when DI1=OFF
No function	Hides the LOCK parameter when DI1=ON. Shows the LOCK parameter when DI1=OFF.
No function	AUTO when DI2=ON MAN when DI2=OFF
Common	Common
When DIS=2	When switching target SP 1 to 4. 1.SP: SP1-SP4 DI1 OFF ON OFF ON DI2 OFF OFF ON ON
Common	Common
When DIS=3	When DIS=3 2.SP when DI1=ON 1.SP when DI1=OFF
Common	Common
When DIS=4	When DIS=4 2.SP when DI1=ON 1.SP when DI1=OFF STOP when DI2=ON RUN when DI2=OFF
Common	Common

Correspondence between parameter OT and control output types

Correspondence between parameter OT and control output types	
OT=0 (factory-shipped setting)	OT=2 Current output (terminals ⑩ and ⑪)
Time proportional control Relay output (terminals ①, ② and ③)	OT=3 On-off control Relay output (terminals ①, ② and ③)

Correspondence between parameter OT and control output types

Correspondence between parameter OT and control output types	
OT=0 (factory-shipped setting)	OT=2 Current output (terminals ⑩ and ⑪)
Time proportional control Relay output (terminals ①, ② and ③)	OT=3 On-off control Relay output (terminals ①, ② and ③)

Note: External Contact Input  
If the power is turned on when the external contact input is OFF, the mode (SP:NO or AM) existing before the power is turned off will be continued.  
(except for RUN/STOP)

# Heating/Cooling Type, Terminal Arrangements

**Heating-side control output**

Relay contact output

NC NO COM

Contact rating: 250 V AC, 3 A  
30 V DC, 3 A (resistance load)

Alarm output/cooling-side control output

AL1 AL2 AL3 COM

Relay contact rating: 240 V AC, 1 A  
30 V DC, 1 A (resistance load)

Note: The cooling-side control output is selected if 4, 5 or 6 is set in the OT (Control Output Type) setup parameter. The alarm-3 output is not available. The controller is factory-set to the cooling-side control output (time proportional PID relay contact output).

**Power supply**

CAUTION

Before carrying out wiring, turn off the power to the controller and check that cables to be connected are not alive with a tester or the like because there is a possibility of electric shock.

Allowable range: 100 to 240 V AC (±10%)  
(free voltage)  
50/60 Hz shared

\* This wiring is only possible for a controller with a heater burnout alarm.

**RS-485 communication**

23 SDB(+)  
24 SDA(-)  
25 RDB(+)  
26 RDA(-)  
27 SG

**PV input** \* Not configured at factory before shipment

TC input

RTD input

mV/V input

\* Wiring can only be carried out for controllers with communication functions.  
Maximum baud rate: 9600 bps

**Receiving 4-20 mA DC Current Signals with the Controller**

\* When receiving 4-20 mA DC current signals, set the PV input type to 4-5 V DC (sepost: "41").

Note: Connecting a 250 Ω resistor to the terminals is optional.  
Model: X010-250-2 (resistor with M3.5 crimp-on terminal lugs)

**Heating-side control output**

Current/voltage pulse output

\* Available if 5, 6, 8, 9, 11 or 12 is set in the OT (Control Output Type) setup parameter.

**Retransmission output**

15 V DC loop power supply

4-20 mA DC

14.5-16.0V DC (21 mA DC max.)

\* PV retransmission is configured at factory before shipment.

**Cooling-side control output**

4-20 mA DC voltage pulse (12 V)

\* If 15 V DC loop power supply is used, retransmission output cannot be used.

\* The retransmission output and 15 V DC loop power supply are not available if the cooling-side control output is set to "continuous output" and "voltage pulse output."

**External Contact Input**

If the power is turned on when the external contact input is OFF, the mode (SP NO or AM) existing before the power is turned off will be continued.  
(except for RUNSTOP)

Contact rating: 12 V DC, 10 mA or more

**Correspondence between parameter DIS and external contact input functions**

When DIS=1 (Factory-shipped setting)	When DIS=2	When DIS=3	When DIS=4	When DIS=5	When DIS=6	When DIS=7	When DIS=8	When DIS=9	When DIS=10	When DIS=11	When DIS=12
When DIS=OFF	When DIS=OFF	When DIS=OFF	When DIS=OFF	When DIS=OFF	When DIS=OFF	When DIS=OFF	When DIS=OFF	When DIS=OFF	When DIS=OFF	When DIS=OFF	When DIS=OFF
No function	Hides the LOCK parameter when DI1=ON Shows the LOCK parameter when DI1=OFF	When switching target SP 1 to 4	2.SP when DI1=ON 1.SP when DI1=OFF	2.SP when DI1=ON 1.SP when DI1=OFF	2.SP when DI1=ON 1.SP when DI1=OFF	2.SP when DI1=ON 1.SP when DI1=OFF	2.SP when DI1=ON 1.SP when DI1=OFF	2.SP when DI1=ON 1.SP when DI1=OFF	2.SP when DI1=ON 1.SP when DI1=OFF	2.SP when DI1=ON 1.SP when DI1=OFF	2.SP when DI1=ON 1.SP when DI1=OFF
No function	No function	DI OFF ON OFF ON DI2 OFF ON OFF ON	STOP when DI2=ON RUN when DI2=OFF	STOP when DI2=ON RUN when DI2=OFF	STOP when DI2=ON RUN when DI2=OFF	STOP when DI2=ON RUN when DI2=OFF	STOP when DI2=ON RUN when DI2=OFF	STOP when DI2=ON RUN when DI2=OFF	STOP when DI2=ON RUN when DI2=OFF	STOP when DI2=ON RUN when DI2=OFF	STOP when DI2=ON RUN when DI2=OFF
Common	Common	Common	Common	Common	Common	Common	Common	Common	Common	Common	Common

**Correspondence between parameter OT and heating-side/cooling-side output types**

OT=4 (factory-shipped setting)	OT=5	OT=6	OT=7	OT=8	OT=9	OT=10	OT=11	OT=12
Heating side: Relay output (terminals ①, ② and ③) Cooling side: Relay output (terminals ④ and ⑤)	Heating side: Voltage pulse output (terminals ⑥ and ⑦) Cooling side: Voltage pulse output (terminals ⑧ and ⑨)	Heating side: Current output (terminals ⑩ and ⑪) Cooling side: Voltage pulse output (terminals ⑫ and ⑬)	Heating side: Relay output (terminals ⑭, ⑮ and ⑯) Cooling side: Voltage pulse output (terminals ⑰ and ⑱)	Heating side: Voltage pulse output (terminals ⑲ and ⑳) Cooling side: Voltage pulse output (terminals ㉑ and ㉒)	Heating side: Current output (terminals ㉓ and ㉔) Cooling side: Voltage pulse output (terminals ㉕ and ㉖)	Heating side: Relay output (terminals ㉗ and ㉘) Cooling side: Current output (terminals ㉙ and ㉚)	Heating side: Voltage pulse output (terminals ㉛ and ㉜) Cooling side: Current output (terminals ㉝ and ㉞)	Heating side: Current output (terminals ㉟ and ㊱) Cooling side: Current output (terminals ㊲ and ㊳)

The control output types, "relay output" and "voltage pulse output" shown in the table above refer to those of time proportional control. To change the type to a relay output for on-off control, select "Relay Terminals" and change the setpoint of the proportional band to "0."

## External Dimensions and Panel Cutout Dimensions

Unit: mm

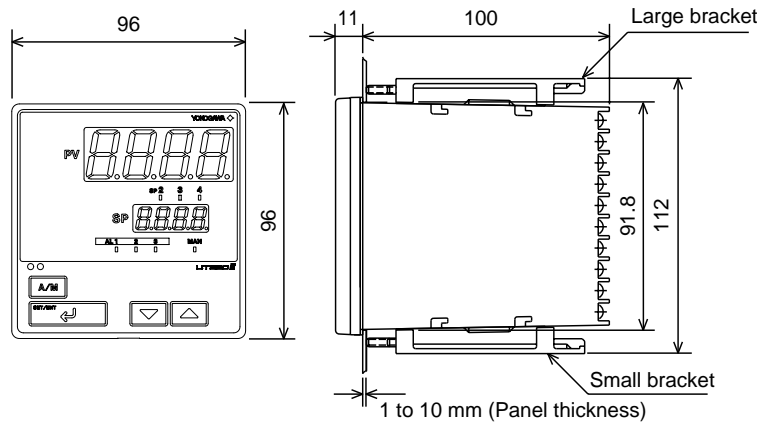

General installation

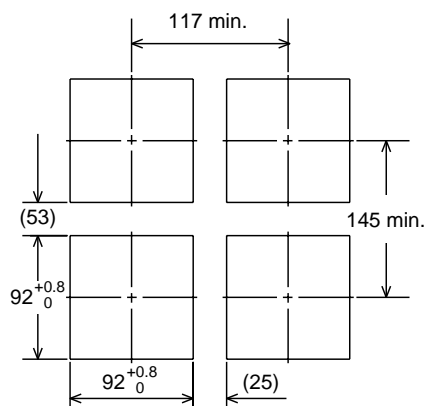

Side-by-side close installation

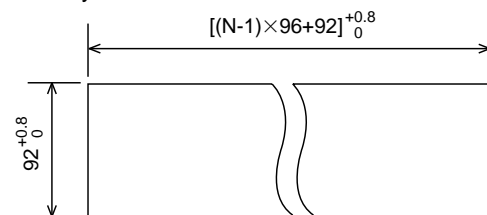

"N" stands for the number of controllers to be installed.  
However, the measured value applies if  $N \geq 5$ .

## Model and Suffix codes

Model	Suffix Code	Description
UT350		Digital indicating controller (provided with retransmission output and 15 V DC loop power supply as standard)
Type	-0	Standard type
	-2	Heating/cooling type
	-3	Standard type (with 24 V DC loop power supply)
Optional functions	0	None
	1	With communication, Heater burnout alarm
	2	With heater burnout alarm

Standard Accessories: Brackets (mounting hardware), unit label, User's Manuals, and User's Manual (reference) (CD-ROM version)

## Items to be specified when ordering

Model and suffix codes, necessary/unnecessary of User's Manual or QIC.